

Sodium-cooled fast reactor

A **sodium-cooled fast reactor** is a fast neutron reactor cooled by liquid sodium.

The initials **SFR** in particular refer to two Generation IV reactor proposals, one based on existing liquid metal cooled reactor (LMFR) technology using mixed oxide fuel (MOX), and one based on the metal-fueled integral fast reactor.

Several sodium-cooled fast reactors have been built and some are in current operation, particularly in Russia.^[1] Others are in planning or under construction. For example, in 2022, in the US, TerraPower (using its Traveling Wave technology^[2]) is planning to build its own reactors along with molten salt energy storage^[2] in partnership with GEHitachi's PRISM integral fast reactor design, under the *Natrium*^[3] appellation in Kemmerer, Wyoming.^{[4][5]}

Aside from the Russian experience, Japan, India, China, France and the USA are investing in the technology.

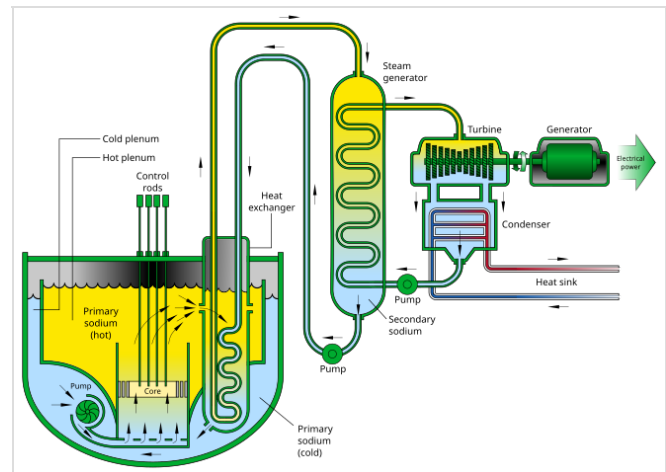

Pool type sodium-cooled fast reactor (SFR)

Fuel cycle

The nuclear fuel cycle employs a full actinide recycle with two major options: One is an intermediate-size (150–600 MWe) sodium-cooled reactor with uranium-plutonium-minor-actinide-zirconium metal alloy fuel, supported by a fuel cycle based on pyrometallurgical reprocessing in facilities integrated with the reactor. The second is a medium to large (500–1,500 MWe) sodium-cooled reactor with mixed uranium-plutonium oxide fuel, supported by a fuel cycle based upon advanced aqueous processing at a central location serving multiple reactors. The outlet temperature is approximately 510–550 degrees C for both.

Sodium coolant

Liquid metallic sodium may be used to carry heat from the core. Sodium has only one stable isotope, sodium-23, which is a weak neutron absorber. When it does absorb a neutron it produces sodium-24, which has a half-life of 15 hours and decays to stable isotope magnesium-24.

Pool or loop type

The two main design approaches to sodium-cooled reactors are pool type and loop type.

In the pool type, the primary coolant is contained in the main reactor vessel, which therefore includes the reactor core and a heat exchanger. The US EBR-2, French Phénix and others used this approach, and it is used by India's Prototype Fast Breeder Reactor and China's CFR-600.

In the loop type, the heat exchangers are outside the reactor tank. The French Rapsodie, British Prototype Fast Reactor and others used this approach.

Advantages

All fast reactors have several advantages over the current fleet of water based reactors in that the waste streams are significantly reduced. Crucially, when a reactor runs on fast neutrons, the plutonium isotopes are far more likely to fission upon absorbing a neutron. Thus, fast neutrons have a smaller chance of being captured by the uranium and plutonium, but when they are captured, have

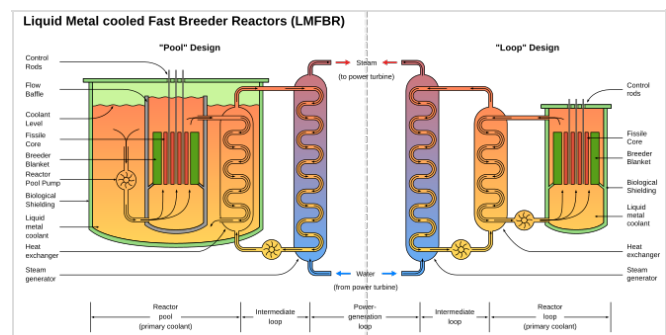

Schematic diagram showing the difference between the Pool and Loop designs of a liquid metal fast breeder reactor

a much bigger chance of causing a fission. This means that the inventory of transuranic waste is non-existent from fast reactors.

The primary advantage of liquid metal coolants, such as liquid sodium, is that metal atoms are weak neutron moderators. Water is a much stronger neutron moderator because the hydrogen atoms found in water are much lighter than metal atoms, and therefore neutrons lose more energy in collisions with hydrogen atoms. This makes it difficult to use water as a coolant for a fast reactor because the water tends to slow (moderate) the fast neutrons into thermal neutrons (although concepts for reduced moderation water reactors exist).

Another advantage of liquid sodium coolant is that sodium melts at 371K (98°C) and boils / vaporizes at 1156K (883°C), a difference of 785K (785°C) between solid / frozen and gas / vapor states. By comparison, the liquid temperature range of water (between ice and gas) is just 100K at normal, sea-level atmospheric pressure conditions. Despite sodium's low specific heat (as compared to water), this enables the absorption of significant heat in the liquid phase, while maintaining large safety margins. Moreover, the high thermal conductivity of sodium effectively creates a reservoir of heat capacity that provides thermal inertia against overheating.^[6] Sodium need not be pressurized since its boiling point is much higher than the reactor's operating temperature, and sodium does not corrode steel reactor parts, and in fact, protects metals from corrosion.^[6] The high temperatures reached by the coolant (the Phénix reactor outlet temperature was 833K (560°C)) permit a higher thermodynamic efficiency than in water cooled reactors.^[7] The electrically conductive molten sodium can be moved by electromagnetic pumps.^[7] The fact that the sodium is not pressurized implies that a much thinner reactor vessel can be used (e.g. 2 cm thick). Combined with the much higher temperatures achieved in the reactor, this means that the reactor in shutdown mode can be passively cooled. For example, air ducts can be engineered so that all the decay heat after shutdown is removed by natural convection, and no pumping action is required. Reactors of this type are self-controlling. If the temperature of the core increases, the core will expand slightly, which means that more neutrons will escape the core, slowing down the reaction.

Disadvantages

A disadvantage of sodium is its chemical reactivity, which requires special precautions to prevent and suppress fires. If sodium comes into contact with water it reacts to produce sodium hydroxide and hydrogen, and the hydrogen burns in contact with air. This was the case at the Monju Nuclear Power Plant in a 1995 accident. In addition, neutron capture causes it to become radioactive; albeit with a half-life of only 15 hours.^[6]

Another problem is leaks. Sodium at high temperatures ignites in contact with oxygen. Such sodium fires can be extinguished by powder, or by replacing the air with nitrogen. A Russian breeder reactor, the BN-600, reported 27 sodium leaks in a 17-year period, 14 of which led to sodium fires.^[8]

Design goals

The operating temperature must not exceed the fuel's boiling temperature. Fuel-to-cladding chemical interaction (FCCI) has to be accommodated. FCCI is eutectic melting between the fuel and the cladding; uranium, plutonium, and lanthanum (a fission product) inter-diffuse with the iron of the cladding. The alloy that forms has a low eutectic melting temperature. FCCI causes the cladding to reduce in strength and even rupture. The amount of transuranic transmutation is limited by the production of plutonium from uranium. One work-around is to have an inert matrix, using, e.g., magnesium oxide. Magnesium oxide has an order of magnitude lower probability of interacting with neutrons (thermal and fast) than elements such as iron.^[14]

High-level wastes and, in particular, management of plutonium and other actinides must be handled. Safety features include a long thermal response time, a large margin to coolant boiling, a primary cooling system that operates near atmospheric pressure, and an intermediate sodium system between the radioactive sodium in the primary system and the water and steam in the power plant. Innovations can reduce capital cost, such as modular designs,

Actinides and fission products by half-life									
Actinides ^[9] by decay chain				Half-life range (a)	Fission products of ²³⁵ U by yield ^[10]				
4n	4n + 1	4n + 2	4n + 3		4.5–7%	0.04–1.25%	<0.001%		
²²⁸ Ra ^{Ne}				4–6 a		¹⁵⁵ Eu ^b			
²⁴⁸ Bk ^[11]				> 9 a					
²⁴⁴ Cm ^f	²⁴¹ Pu ^f	²⁵⁰ Cf	²²⁷ Ac ^{Ne}	10–29 a	⁹⁰ Sr	⁸⁵ Kr	^{113m} Cd ^b		
²³² U ^f		²³⁸ Pu ^f	²⁴³ Cm ^f	29–97 a	¹³⁷ Cs	¹⁵¹ Sm ^b	^{121m} Sn		
	²⁴⁹ Cf ^f	^{242m} Am ^f		141–351 a					
	²⁴¹ Am ^f		²⁵¹ Cf ^f ^[12]	430–900 a					
		²²⁶ Ra ^{Ne}	²⁴⁷ Bk	1.3–1.6 ka	No fission products have a half-life in the range of 100 a–210 ka ...				
²⁴⁰ Pu	²²⁹ Th	²⁴⁶ Cm ^f	²⁴³ Am ^f	4.7–7.4 ka					
	²⁴⁵ Cm ^f	²⁵⁰ Cm		8.3–8.5 ka					
			²³⁹ Pu ^f	24.1 ka					
		²³⁰ Th ^{Ne}	²³¹ Pa ^{Ne}	32–76 ka					
²³⁶ Np ^f	²³³ U ^f	²³⁴ U ^{Ne}		150–250 ka	⁹⁹ Tc ^ϕ	¹²⁶ Sn			
²⁴⁸ Cm		²⁴² Pu		327–375 ka		⁷⁹ Se ^ϕ			
				1.33 Ma	¹³⁵ Cs ^ϕ				
	²³⁷ Np ^f			1.61–6.5 Ma	⁹³ Zr	¹⁰⁷ Pd			
²³⁶ U			²⁴⁷ Cm ^f	15–24 Ma		¹²⁹ I ^ϕ			
²⁴⁴ Pu				80 Ma	... nor beyond 15.7 Ma ^[13]				
²³² Th ^{Ne}		²³⁸ U ^{Ne}	²³⁵ U ^f ^{Ne}	0.7–14.1 Ga					

ϕ, has thermal neutron capture cross section in the range of 8–50 barns
 f, fissile
 Ne, primarily a naturally occurring radioactive material (NORM)

removing a primary loop, integrating the pump and intermediate heat exchanger, and better materials.^[15]

b, neutron poison (thermal neutron capture cross section greater than 3k barns)

The SFR's fast spectrum makes it possible to use available fissile and fertile materials (including depleted uranium) considerably more efficiently than thermal spectrum reactors with once-through fuel cycles.

History

In 2020 Natrium received an \$80M grant from the US Department of Energy for development of its SFR. The program plans to use High-Assay, Low Enriched Uranium fuel containing 5-20% uranium. The reactor was expected to be sited underground and have gravity-inserted control rods. Because it operates at atmospheric pressure, a large containment shield is not necessary. Because of its large heat storage capacity, it was expected to be able to produce surge power of 500 MWe for 5+ hours, beyond its continuous power of 345 MWe.^[16]

Reactors

Sodium-cooled reactors have included:

Model	Country	Thermal power (MW)	Electric power (MW)	Year of commission	Year of decommission	Notes
<u>BN-350</u>	 Soviet Union		350	1973	1999	Was used to power a water de-salination plant.
<u>BN-600</u>	 Soviet Union		600	1980	Operational	Together with the BN-800, one of only two commercial fast reactors in the world.
<u>BN-800</u>	 Soviet Union/ Russia	2100	880	2015	Operational	Together with the BN-600, one of only two commercial fast reactors in the world.
<u>BN-1200</u>	 Russia	2900	1220	<i>2036</i>	Not yet constructed	In development. Will be followed by BN-1200M as a model for export.
<u>CEFR</u>	 China	65	20	2012	Operational	
<u>CFR-600</u>	 China	1500	600	2023	Under construction	Two reactors being constructed on Changbiao Island in Xiapu County. The second CFR-600 reactor will open in 2026. ^[17]
<u>CRBRP</u>	 United States	1000	350	Never built		
<u>EBR-1</u>	 United States	1.4	0.2	1950	1964	
<u>EBR-2</u>	 United States	62.5	20	1965	1994	
<u>Fermi 1</u>	 United States	200	69	1963	1975	
<u>Sodium Reactor Experiment</u>	 United States	20	6.5	1957	1964	
<u>S1G</u>	 United States					<u>United States naval reactors</u>
<u>S2G</u>	 United States					<u>United States naval reactors</u>
<u>Fast Flux Test Facility</u>	 United States	400		1978	1993	Not for power generation
<u>PFR</u>	 United Kingdom	500	250	1974	1994	
<u>FBTR</u>	 India	40	13.2	1985	Operational	
<u>PFBR</u>	 India		500	2024	Under commissioning	
<u>Monju</u>	 Japan	714	280	1995/2010	2010	Suspended for 15 years. Reactivated in 2010, then permanently closed
<u>Jōyō</u>	 Japan	150		1971	Operational	
<u>SNR-300</u>	 Germany		327	1985	1991	Never critical/operational
<u>Rapsodie</u>	 France	40	24	1967	1983	
<u>Phénix</u>	 France	590	250	1973	2010	
<u>Superphénix</u>	 France	3000	1242	1986	1997	Largest SFR ever built.
<u>ASTRID</u>	 France		600	Never built		2012–2019 €735 million spent

Most of these were experimental plants that are no longer operational. On November 30, 2019, CTV reported that the Canadian provinces of New Brunswick, Ontario and Saskatchewan planned an announcement about a joint plan to cooperate on small sodium fast modular nuclear reactors from New Brunswick-based ARC Nuclear Canada.^[18]

See also

- Fast breeder reactor
- Fast neutron reactor
- Integral fast reactor
- Lead-cooled fast reactor
- Gas-cooled fast reactor
- Generation IV reactor

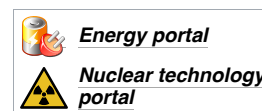

References

- "Fast Neutron Reactors | FBR - World Nuclear Association" (<https://world-nuclear.org/information-library/current-and-future-generation/fast-neutron-reactors.aspx>). *world-nuclear.org*.
- Patel, Sonal (2020-09-03). "GE Hitachi, TerraPower Team on Nuclear-Storage Hybrid SMR" (<https://www.powermag.com/ge-hitachi-terrapower-team-on-nuclear-storage-hybrid-smr/>). *POWER Magazine*. Retrieved 2022-10-28.
- "Natrium" (<https://www.nrc.gov/reactors/new-reactors/advanced/licensing-activities/pre-application-activities/natrium.html>). *NRC Web*. Retrieved 2022-10-28.
- Patel, Sonal (2022-10-27). "PacifiCorp, TerraPower Evaluating Deployment of Up to Five Additional Natrium Advanced Reactors" (<https://www.powermag.com/pacificorp-terrapower-evaluating-deployment-of-up-to-five-additional-natrium-advanced-reactors/>). *POWER Magazine*. Retrieved 2022-10-28.
- Gardner, Timothy (August 28, 2020). "Bill Gates' nuclear venture plans reactor to complement solar, wind power boom" (<https://www.reuters.com/article/us-usa-nuclearpower-terrapower-idUSKBN25N2U8>). *Reuters* – via www.reuters.com.
- Fanning, Thomas H. (May 3, 2007). "Sodium as a Fast Reactor Coolant" (https://web.archive.org/web/20130113134710/http://www.ne.doe.gov/pdfFiles/SodiumCoolant_NRCpresentation.pdf) (PDF). Topical Seminar Series on Sodium Fast Reactors. Nuclear Engineering Division, U.S. Nuclear Regulatory Commission, U.S. Department of Energy. Archived from the original (http://www.ne.doe.gov/pdfFiles/SodiumCoolant_NRCpresentation.pdf) (PDF) on January 13, 2013.
- Bonin, Bernhard; Klein, Etienne (2012). *Le nucléaire expliqué par des physiciens*.
- Unusual occurrences during LMFR operation (https://www-pub.iaea.org/MTCD/Publications/PDF/te_1180_prn.pdf), Proceedings of a Technical Committee meeting held in Vienna, 9–13 November 1998, IAEA. Page 53, 122-123.
- Plus radium (element 88). While actually a sub-actinide, it immediately precedes actinium (89) and follows a three-element gap of instability after polonium (84) where no nuclides have half-lives of at least four years (the longest-lived nuclide in the gap is radon-222 with a half life of less than four *days*). Radium's longest lived isotope, at 1,600 years, thus merits the element's inclusion here.
- Specifically from thermal neutron fission of uranium-235, e.g. in a typical nuclear reactor.
- Milsted, J.; Friedman, A. M.; Stevens, C. M. (1965). "The alpha half-life of berkelium-247; a new long-lived isomer of berkelium-248". *Nuclear Physics*. **71** (2): 299. Bibcode:1965NucPh..71..299M (<https://ui.adsabs.harvard.edu/abs/1965NucPh..71..299M>). doi:10.1016/0029-5582(65)90719-4 (<https://doi.org/10.1016%2F0029-5582%2865%2990719-4>). "The isotopic analyses disclosed a species of mass 248 in constant abundance in three samples analysed over a period of about 10 months. This was ascribed to an isomer of Bk²⁴⁸ with a half-life greater than 9 [years]. No growth of Cf²⁴⁸ was detected, and a lower limit for the β[−] half-life can be set at about 10⁴ [years]. No alpha activity attributable to the new isomer has been detected; the alpha half-life is probably greater than 300 [years]."
- This is the heaviest nuclide with a half-life of at least four years before the "sea of instability".
- Excluding those "classically stable" nuclides with half-lives significantly in excess of ²³²Th; e.g., while ^{113m}Cd has a half-life of only fourteen years, that of ¹¹³Cd is eight quadrillion years.
- Bays SE, Ferrer RM, Pope MA, Forget B (February 2008). "Neutronic Assessment of Transmutation Target Compositions in Heterogeneous Sodium Fast Reactor Geometries" (<https://web.archive.org/web/20120212184011/http://www.inl.gov/technicalpublications/Documents/3901052.pdf>) (PDF). Idaho National Laboratory, U.S. Department of Energy. INL/EXT-07-13643 Rev. 1. Archived from the original (<https://www.inl.gov/technicalpublications/Documents/3901052.pdf>) (PDF) on 2012-02-12.
- Lineberry MJ, Allen TR (October 2002). "The Sodium-Cooled Fast Reactor (SFR)" (<https://web.archive.org/web/20170329111828/http://www.ipd.anl.gov/anlpubs/2002/10/44547.pdf>) (PDF). Argonne National Laboratory, US Department of Energy. ANL/NT/CP-108933. Archived from the original (<http://www.ipd.anl.gov/anlpubs/2002/10/44547.pdf>) (PDF) on 2017-03-29. Retrieved 2012-05-01.
- "Bill Gates's next-gen nuclear plant packs in grid-scale energy storage" (<https://newatlas.com/energy/natrium-molten-salt-nuclear-reactor-storage/>). *New Atlas*. 2021-03-09. Retrieved 2021-06-03.
- "China Fast Reactor 600 to be Launched in 2023, 2026 Draws International Attention | Tech Times" (<https://www.techtimes.com/articles/260677/20210526/china-fast-reactor-600-launched-2023-2026-draw-international-attention.htm>).
- "Three premiers plan to fight climate change by investing in small nuclear reactors" (<https://www.ctvnews.ca/politics/three-premier-s-plan-to-fight-climate-change-by-investing-in-small-nuclear-reactors-1.4709865>). *CTVNews*. November 30, 2019.

External links

- Idaho National Laboratory Sodium-cooled Fast Reactor Fact Sheet (<https://www.inl.gov/research/sodium-cooled-fast-reactor/>)
- Generation IV International Forum SFR website (<https://web.archive.org/web/20060218062116/http://www.gen-4.org/Technology/systems/sfr.htm>)
- INL SFR workshop summary (https://wayback.archive-it.org/all/20060305145004/http://neri.inel.gov/program_plans/pdfs/appendix_5.pdf)
- ALMR/PRISM (<https://web.archive.org/web/20051227075153/http://www.nuc.berkeley.edu/~gav/almr/01.intro.html>)
- ASME (<http://proceedings.asmedigitalcollection.asme.org/proceeding.aspx?articleid=1762221>)
- Richardson JH (November 17, 2009). "Meet the Man Who Could End Global Warming" (<https://web.archive.org/web/20091121055813/http://www.esquire.com/features/best-and-brightest-2009/nuclear-waste-disposal-1209-2>). *Esquire*. Archived from the original (<http://www.esquire.com/features/best-and-brightest-2009/nuclear-waste-disposal-1209-2>) on November 21, 2009. "... Eric Loewen is the evangelist of the sodium fast reactor, which burns nuclear waste, emits no CO₂, ..."

Retrieved from "https://en.wikipedia.org/w/index.php?title=Sodium-cooled_fast_reactor&oldid=1260977031"

